

# SunWorks

## SB1C Solar Charge Controller Specification

Operating Voltage	6.5 to 17	Volts (12V nominal)
Solar Current	10	Amps max
Battery types	Gel and liquid	Lead acid
Dimensions	110w85h35d	mm
Weight	200	g
Display	LCD	32 characters
Display resolution	0.1	Volts and amps
Charge modes	Boost	For 2hrs or until battery reaches 14.4V. Boost mode recommences if battery falls below 12.4V, or if solar current falls to zero.
	PWM	14.4V. Boost and PWM for 2hrs max
	Float	13.8V continuous
Other modes	No solar	Night-time or too dark.
	Overcurrent	Max current exceeded. Charging stops for 2hrs
	Error	Battery faulty
PWM frequency	30	Hz
Self consumption	6.5	mA
Energy Loss at full current	< 3.5	Watts
Maximum solar voltage	35	Volts
Regulation type	Series	
Operating temperature	-10 to +50	Deg Celsius
Storage temperature	-20 to +60	Deg Celsius
Humidity	5 to 95	%
Case Material	Recyclable plastic, black or light grey	
Protection	IP55	
Connection type	Screw terminal blocks	
Wire type	2.5	mm multi-strand
Wire length, battery	3.5	meters, Max
Wire length, solar panel	8	meters, Max
Fixing	Wall mounted. Fixed with two screws	

High specification Solar Charge Controller specially designed for Mobile Homes, Yachts and Narrowboats.  
Essential protection from battery overcharging.  
Displays solar current and battery voltage.  
Fully automatic operation.  
No setting up routine.  
High reliability.  
Small size.  
Rear cable entry for hidden wiring.

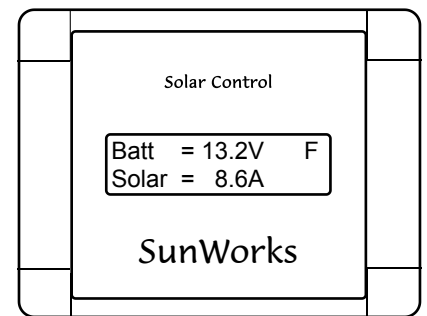

Available in black or light grey

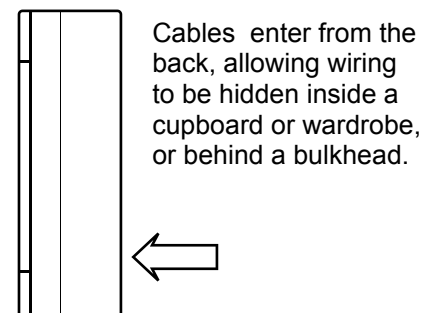

Cables enter from the back, allowing wiring to be hidden inside a cupboard or wardrobe, or behind a bulkhead.

SunWorks  
1, Place de l'Eglise  
17160 Louzignac  
France

Tel: 00 33 546 58 66 17  
Email: [sales@sunworks.co.uk](mailto:sales@sunworks.co.uk)  
[www.sunworks.co.uk](http://www.sunworks.co.uk)

## SB1C Photovoltaic Charge Controller

For 12 Volt systems. 10amps max.

Installation and Operating Instructions

# SunWorks

### OPERATION:

The SB1C is fully automatic in operation and requires no setting-up procedure. The display will show the battery voltage in volts, and the solar current in amps. The display will also show the charge mode. This is varied automatically according to the state of charge of the battery. The controller is designed to maximise the battery charge for the given conditions. Note that the current is automatically adjusted by the charge controller in accordance with the charge mode in use, and so will not always reflect the maximum current available from the solar panel. For example, if the charge controller is in FLOAT mode, the battery is fully charged and the controller is only allowing a small maintenance current through to the battery. The charge modes are as follows:

- N NO solar current is available for charging.
- B BOOST mode. Used at the start of each day or if the battery voltage falls below 12.4V.
- P PWM mode. Takes over from Boost mode when the battery voltage reaches 14.4V. Progressively reduces the solar current to maintain this voltage. For a maximum of 2 hours.
- F FLOAT. Maintenance charge. Solar current controlled to maintain the battery voltage at 13.8V.
- M MAXCURRENT. The solar panels are producing too much current for this controller. The current will be switched off for 2 hours. Please refer to your supplier.

### GUARANTEE:

This product is guaranteed against faulty materials or workmanship for 2 years from the date of purchase. This does not affect your statutory rights.

Please return the unit, together with proof of purchase to:

## SunWorks

1 Place de l'Eglise  
17160 Louzignac  
France  
Tel: 00 33 546 58 66 17  
Email: sales@sunworks.co.uk

### INSTALLATION:

1. Please read through all the instructions before commencing installation.
  2. Position the controller on a vertical, non-flammable, solid dry surface. This is usually on the side of a cupboard or bulkhead. The battery cables must not exceed 3.5m in length. The cables to the solar panels can be longer but must run uninterrupted to the solar panels. Ensure that there is at least 150mm of clear space all around the controller. Fixing is by two holes through the back of the controller. The wires are passed through the large hole in the back of the controller, and attach to the internal connection block.
  3. Holding the base of the unit in place, mark the position of the two fixing holes and the position of the cable hole. Drill two 2.5mm holes for the fixing screws and a 14mm hole for the cables. Attach the controller using two suitable screws.
  4. Cables between the solar panel, battery and controller must be 2.5mm sq. multi-stranded, and must be supported at intervals of 300mm. Battery cables must run directly to the battery. A 10 amp fuse must be fitted in the battery positive cable. Before connecting the controller, cover the solar panel and remove the fuse. Strip the cable back 10mm and secure in the terminal block as per the diagram below.
- If in doubt please consult a qualified electrician.
5. When replacing the lid ensure that the cables pass directly from the terminal block to the exit hole, and that no cables are trapped. Fit the four corner inserts.
  6. Fit the battery fuse, and uncover the solar panel.

### CONNECTIONS:

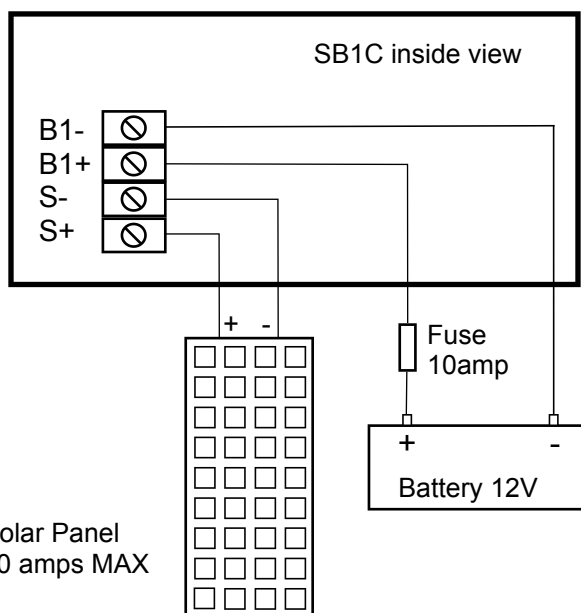

### DISCONNECTION:

Cover the solar panels and remove the battery fuse before disconnecting the charge controller.