

Operating Voltage	6.5 to 17	Volts (12 V nominal)
Solar Current	20	Amps max
Battery types	Lead acid	Gel or liquid, switch selectable.
Dimensions	145w 123h 45d	mm
Weight	340	g
Indicator	Yellow LED	Flashes when charging ON when charged.
Charge modes. Note: the indication of all charge modes and other modes is by the optional remote display unit only.	Boost	For 2 hrs or until battery reaches 14.4 V. Recommences if battery falls below 12.4 V, or if solar current falls to zero.
	PWM	Maintains 14.4 V. Boost and PWM for 2 hrs max
	Float	13.8 / 14.0V, liq / gel
Other modes	No solar	Night-time or too dark.
	MaxSolar	Max solar current exceeded. Charging stops for 2 hrs.
	Error	Battery faulty
	Cooling	Excessive heat. Charge off. Waiting for lower temperature.
PWM frequency	30	Hz
Self consumption	5.5	mA
Energy Loss	< 6	Watts, (when solar current reaches 20 amps)
Maximum solar voltage	35	Volts
Regulation type	Series	
Temp. Co. of set points	-30	mV / deg Celsius
Operating temperature	-10 to +50	Deg Celsius
Storage temperature	-20 to +60	Deg Celsius
Humidity	5 to 95	%
Case Material	Recyclable plastic, black.	
Protection	IP22	
Connection type	Ring terminals, standard automotive.	
Wire type	4	Sq mm. multi-stranded
Wire length, battery	2	meters, Max
Wire length, solar panel	10	meters, Max
Fixing	Wall mounted. Fixed with two screws	

High specification Solar Charge Controller specially designed for Mobile Homes, Yachts and Narrow boats.
Essential protection from battery overcharging.
Heatsink not in contact with mounting surface.
Very low heat dissipation.
LED Charge Status indicator.
Optional remote display unit shows solar current and battery voltage.
Fully automatic operation.
No setting up routine.
High reliability. Small size.
Ring terminals for secure cable connections.

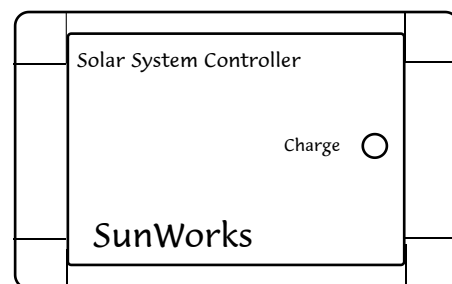

Remote Display unit (optional).
Supplied with 4m cable.

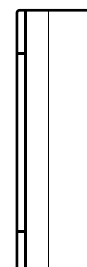
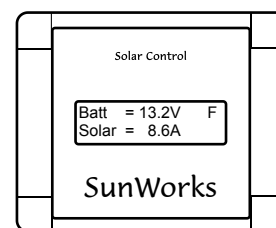

Cable enters from the back, allowing wiring to be hidden inside a cupboard or wardrobe, or behind a bulkhead.

SunWorks
1, Place de l'Eglise
17160 Louzignac
France

Tel: 00 33 546 58 66 17
Email:sales@sunworks.co.uk
www.sunworks.co.uk

SB3C Photovoltaic Charge Controller

For 12 Volt systems. 20amps max.

Installation and Operating Instructions

SunWorks

OPERATION:

The SB3C is fully automatic in operation and requires no setting-up procedure. The charge mode is automatically selected to maximise the charge according to the charge state of the battery.

The Charge LED will flash when the controller is charging. When the battery is charged, the LED will remain ON. If fitted, the Remote Display Unit (optional) shows the battery voltage, the solar current and the charge mode.

Note that the current is automatically adjusted by the charge controller in accordance with the charge mode, and so will not always use the maximum current available from the solar panel. For example, if the charge controller is in FLOAT mode, the battery is fully charged and the controller will only allow a small maintenance current through to the battery.

The charge modes are as follows:

NOSOLAR: Unit is initialising OR no solar current is available for charging.

BOOST: Used at the start of each day or if the battery voltage falls below 12.4 V.

PWM: Takes over from Boost mode when the battery voltage reaches 14.4V. Progressively reduces the solar current to maintain this voltage. For 2 hours maximum.

FLOAT: Maintenance charge. Solar current is controlled to maintain liquid batteries at 13.8 V, gel batteries at 14.0 V.

MAXSOLAR: The solar panels are producing too much current for this controller. The current will be switched off for 2 hours. Reduce you solar panel size to avoid any damage.

COOLING: Charging stopped. Charging will recommence when the temperature has reduced.

GUARANTEE:

This product is guaranteed against faulty materials or workmanship for 2 years from the date of purchase. This does not affect your statutory rights.

Please return the unit, together with proof of purchase to:

SunWorks

1 Place de l'Eglise
17160 Louzignac
France

Tel: 00 33 546 58 66 17

Email: sales@sunworks.co.uk

INSTALLATION:

1. Please read through all the instructions before commencing installation. If in doubt please consult a qualified electrician.

2. The controller must be mounted in a well ventilated area. Position the controller on a vertical, solid, dry, non-flammable surface. Ensure there is at least 150 mm of clear space all around the controller, as the controller can get warm. Fixing is by two holes through the back of the controller.

The battery cables must not exceed 2 m in length and must run directly to the battery via a 25 amp fuse. The cables to the solar panels can be longer (see overleaf). The cables attach to the internal connection points using standard automotive crimped ring terminals.

Note that there can be no external common ground connections between battery and solar panels.

3. Holding the base of the unit in place, mark the position of the two fixing holes. Drill two 2.5 mm holes for the fixing screws. Attach the controller using two suitable screws.

4. The small yellow switch near the base of the controller board should be slid downwards for gel batteries.

5. Cables between the solar panel, battery, and controller must be 4 mm sq. multi-stranded, and must be supported at intervals of 300 mm. The fuse must be fitted in the battery positive cable. Before connecting the controller, cover the solar panel and remove the fuse.

6. When replacing the lid ensure that the cables pass through the slot in the bottom of the case and that no cables are trapped.

7. Fit the battery fuse. Uncover the solar panel. The system will take 20 seconds to initialise.

CONNECTIONS:

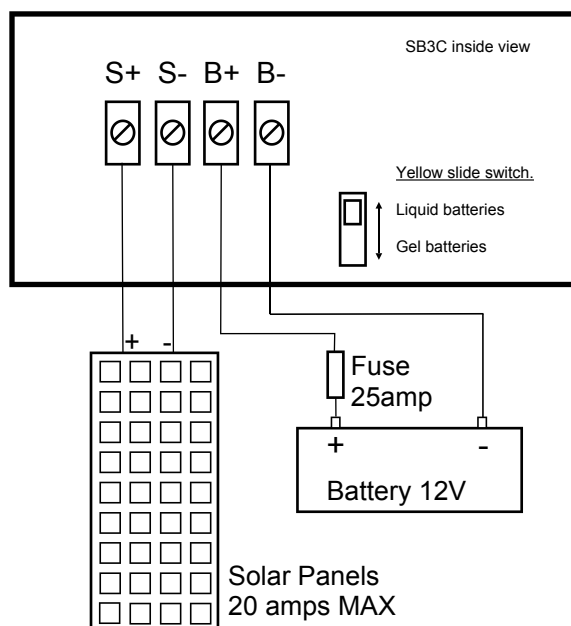

DISCONNECTION:

Always cover the solar panels and remove the battery fuse before disconnecting the charge controller.